

Sliding lock adjustment system

VDS

Sliding lock for oblong hole

- Clamping lock for oblong hole

- Materials:

High pressure die-cast zinc body, chrome-plated
Button in black or orange thermoplastic polyamide
Stainless steel tightening pins and wedges POM
plunger

- Temperature of use: Max. 90°C

Advantages

- Allows locking or unlocking without tools and without screws by simply turning the button
- Saves time by avoiding the handling of tools.

Accessories

- Blocking wedge VDS-CB
- Can be used with a ruler with groove (not supplied).

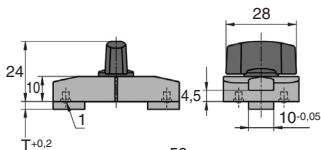

Mounting dimensions of the counterpart

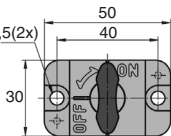
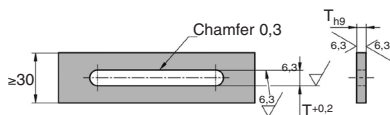

Offset with static load in one direction

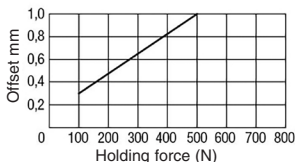

Forces apply to steel or stainless steel plates

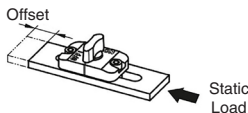

DISCOUNTS

Qty	1+	4+	8+
Disc.	List	-5%	On request

Part number	T1	T2	Holding force (N)	Stock*	Price each 1 to 3
Black button					
VDS50-3/N	3	3	500	-	72,47 €
VDS50-6/N	6	6	500	-	72,47 €
Orange button					
VDS50-3/O	3	3	500	-	72,47 €
VDS50-6/O	6	6	500	-	72,47 €

*Depending on availability - Dimensions in mm

Sliding lock adjustment system

Blocking wedge for sliding lock for oblong hole VDS5CB

- **Blocking wedge necessary for sliding locks for oblong holes with plates thicker than 3mm or 6mm.**

- **Materials:**
Stainless steel natural finish

Accessories

- Sliding lock VDS

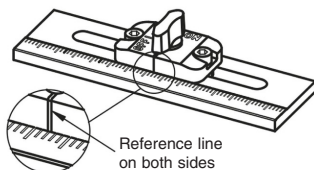
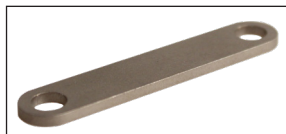

Reference line on both sides

Application example

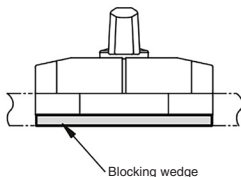

Blocking wedge

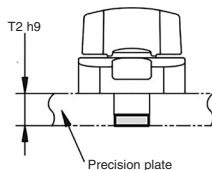
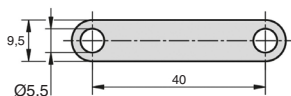

Precision plate

Sliding lock for oblong hole	Suitable blocking wedge	Precision plate T2 (mm)
VDS50-3/N	-	3 _{-0,25}
VDS50-3/O	VDS50-2/CB	5 _{-0,3}
	-	6 _{-0,3}
VDS50-6/N	VDS50-2/CB	8 _{-0,36}
VDS50-6/O	VDS50-3/CB	9 _{-0,36}

DISCOUNTS

Qty	1+	4+	8+
Disc.	List	-5%	On request

Part number	T	Stock*	Price each
VDS50-2/CB	2	-	6,30 €
VDS50-3/CB	3	-	6,79 €

*Depending on availability - Dimensions in mm

Sliding lock adjustment system

VDSQ

Sliding lock for square profile

- Clamping lock for square profile

- Materials:

High pressure die-cast zinc body, chrome-plated
Button in black or orange thermoplastic polyamide
Stainless steel locking pins and wedges
Phosphated bronze leaf spring

- Temperature of use: Max. 90°C



Advantages

- Allows locking or unlocking without tools and without screws by simply turning the button
- Saves time by avoiding the handling of tools.

Accessories

- Blocking wedge VDSQ-CB
- Can be used with a ruler with groove (not supplied).

Mounting dimensions of the square counterpart

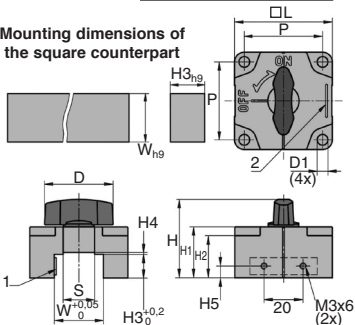

Offset with static load in one direction

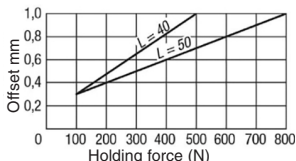

Forces apply to steel or stainless steel square elements

DISCOUNTS

Qty	1+	4+	8+
Disc.	List	-5%	On request

Part number	L	ØD	ØD1	H	H1	H2	H3	H4	H5	P	W	S	Holding force (N)	Stock*	Price each
															1 to 3
Black button															
VDSQ40-12-12/N	40	28	4,5	36	22	18,5	12	-	6,0	32	12	-	500	-	83,48 €
VDSQ40-16-16/N	40	28	4,5	40	26	22,5	16	-	8,0	32	16	-	500	-	83,48 €
VDSQ50-9-25/N	50	35	5,5	37	23	18,5	9	1	4,5	40	25	16	800	-	89,79 €
VDSQ50-12-25/N	50	35	5,5	40	26	21,5	12	1	6,0	40	25	16	800	-	89,79 €
VDSQ50-12-32/N	50	35	5,5	40	26	21,5	12	1	6,0	40	32	16	800	-	89,79 €
VDSQ50-16-32/N	50	35	5,5	44	30	25,5	16	1	8,0	40	32	16	800	-	89,79 €
Orange button															
VDSQ40-12-12/O	40	28	4,5	36	22	18,5	12	-	6,0	32	12	-	500	-	83,48 €
VDSQ40-16-16/O	40	28	4,5	40	26	22,5	16	-	8,0	32	16	-	500	-	83,48 €
VDSQ50-9-25/O	50	35	5,5	37	23	18,5	9	1	4,5	40	25	16	800	-	89,79 €
VDSQ50-12-25/O	50	35	5,5	40	26	21,5	12	1	6,0	40	25	16	800	-	89,79 €
VDSQ50-12-32/O	50	35	5,5	40	26	21,5	12	1	6,0	40	32	16	800	-	89,79 €
VDSQ50-16-32/O	50	35	5,5	44	30	25,5	16	1	8,0	40	32	16	800	-	89,79 €

*Depending on availability - Dimensions in mm

Sliding lock adjustment system

Blocking wedge

VDSQCB

- **Blocking wedge**
- A locking wedge is required for clamp bolts for square profile with a 3mm thick plate.
- They are used to move the clamping lock on a fixed square.
- Materials:
Stainless steel natural finish

Accessory

- Sliding clamping lock VDSQ

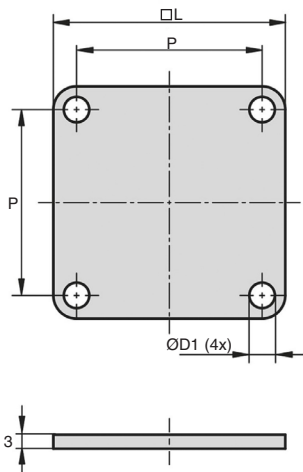
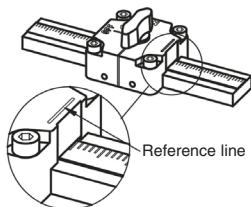
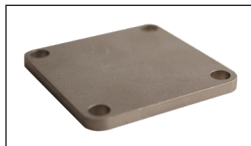

DISCOUNTS

Qty	1+	4+	8+
Disc.	List	-5%	on request

Part number	L	ØD1	P	Stock*	Price each 1 to 3
VDSQ40-32/CB	40	4,5	32	-	8,97 €
VDSQ50-40/CB	50	5,5	40	-	10,54 €

*Depending on availability - Dimensions in mm

Our other products



DOG258

Motor-gearbox 12V and 24V DC, from 12 to 15 Nm



HLUsS

Spoked handwheel, Stainless steel 316



S20

Short housing for open linear bearing, Opened - slim



RPCpl

Fixed castor with plate, Steel - Polyamide



GLT3E-58

Telescopic drawer,



DOMI120

Domino 120 adjustable slide, Slide DOMILINE 120 with counter and han...



RPP

Connecting plate for RPP type timing belts, RPP14



G0

Steel spur gear, Steel 20NCD2



SLH

Horizontal toggle clamp, Horizontal Lever Clamp - steel



PRF4545_P

Stripp Aluminium profile with extendable slot, 45 x 45 mm



GCL

Linear ball slide - Stainless steel balls, Chariot - from 516 N to 8...



TSRTC

Stem support for castor, For swivel castor with central hole

Complementary products