

Split pillow block bearing



SNG

For shafts Ø30 to Ø100

- Two-part split pillow block with a spherical bearing and rollers

- Kit includes:

- 1 cast iron bearing housing
- 1 spherical roller bearing (tapered bore)
- 2 double lipped seals
- 1 H sleeve H for mounting shaft in the tapered bore
- 1 cover
- 2 locknuts

- Materials:

- Cast iron housing
- Steel bearing



Advantages

- Easy assembly and maintenance
- Bearings can be mounted on the shaft before placing them in the housing
- Reduced maintenance costs

Info.

- Lubrication must be used



Complete kit

Part N°	øD	H (h12)	A	E	B	U	V	C	W	L	ød1 (H12)	ød2 (H12)	J
SNG507	30	50	185	150	52	13	20	22	92	82	46,5	54,5	7,5
SNG508	35	60	205	170	60	15	20	25	106	85	51,5	59,5	7,5
SNG509	40	60	205	170	60	15	20	25	109	85	56,5	64,5	8,5
SNG510	45	60	205	170	60	15	20	25	112	90	62	70,5	8,5
SNG511	50	70	255	210	70	18	23	28	127	95	67	75,5	8,5
SNG512	55	70	255	210	70	18	23	30	133	105	72	80,5	8,5
SNG513	60	80	275	230	80	18	24	30	148	110	77	85,5	8,5
SNG515	65	80	280	230	80	18	26	30	154	115	87	95,5	8,5
SNG516	70	95	315	260	90	22	29	32	175	120	92,5	101	10,5
SNG517	75	95	320	260	90	22	30	32	181	125	97,5	106	10,5
SNG518	80	100	345	290	100	22	27	35	192	140	102,5	111	10,5
SNG519	85	112	345	290	100	22	27	35	209	145	131	141	11,5
SNG520	90	112	380	320	110	26	32	40	215	160	137,5	147,5	11,5
SNG522	100	125	410	350	120	26	32	45	239	175	147,5	157,5	11,5

All dimensions in mm



Split pillow block bearing

For shafts Ø30 to Ø100

SNG

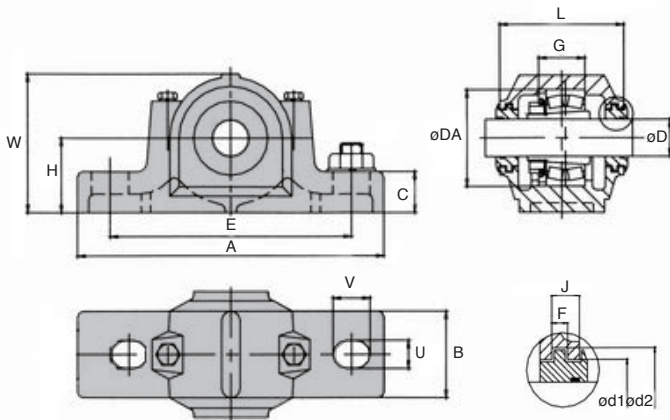

DISCOUNTS

Qty	1+	5+	15+
Disc.	Net -10%	On request	

Part N°	F	G (H12)	øDA (H8)	Oblong hole for screws	Bearing Part N°	Sleeve	Locknut	Price each
SNG507	5	34	72	M10	22207K	H307	SR72x5,5	49,03€
SNG508	5	39	80	M12	22208K	H308	SR80x8	54,12€
SNG509	5	30	85	M12	22209K	H309	SR85x7	58,87€
SNG510	5	41	90	M12	22210K	H310	SR90x9	62,97€
SNG511	5	44	100	M16	22211K	H311	SR100x9,5	75,13€
SNG512	5	48	110	M16	22212K	H312	SR110x10	99,24€
SNG513	5	51	120	M16	22213K	H313	SR120x10	110,22€
SNG515	5	56	130	M16	22215K	H315	SR130x12,5	127,62€
SNG516	5	58	140	M20	22216K	H316	SR140x12,5	156,53€
SNG517	5	61	150	M20	22217K	H317	SR150x12,5	175,69€
SNG518	5	65	160	M20	22218K	H318	SR160x12,5	214,41€
SNG519	6	68	170	M20	22219K	H319	SR170x12,5	279,84€
SNG520	6	70	180	M24	22220K	H320	SR180x12	292,07€
SNG522	6	80	200	M24	22222K	H322	SR200x13,5	370,83€

All dimensions in mm

Fax 0 825 88 6000
 Service 0,15 € / min
 + prix appel

cial2@hpceurope.com

HPC

SUPPLEMENT 2019

129

Our other products



PAM_SS
Stainless steel articulated levelling foot, Ø 30 & 40



EX
Optional shaft for E-type gear reducers, E Gearboxes single sided ou...



PRF_TOOL
Assembly key for aluminium profile, Assembly key



SBF
Sealed flange bearing unit for Food Industry, cover



BPPL
Mini plain bearing ball transfer unit, For countersinking



FFL50
Offset spur gear reducer, from 111 to 425 Nm



RPP
Connecting plate for RPP type timing belts, RPP8



HTD5M_25
HTD Heavy duty timing pulley, HTD5 Aluminium



UTKswcr
Utilitrak® 3 wheels carriage, Steel roller carriage



FBL4004_K32
Brush strip per metre, Black striated polypropylene (PP)



BPMc
Stainless steel slotted spring plunger with ceramic ball tip, 303 St...



CHMX_CHMDX
Shaft for worm and wheel reducer CHMR and CHM, CHMR and CHM gearbox...

Complementary products



UCP
Cast iron pillow block bearing, Cast iron