



# Clamp lever

With male thread

PCLAT  
PCLATss

- Clamp lever with male thread and reduced tip according to DIN 78

- Materials:

Insert: steel (class 5.8) or stainless steel (303)

Handle: glass fibre reinforced polyamide plastic

Mechanism: splined diecast zinc

- Finish: Blackened steel, fine grained surface

- Matte surface with fine grains

- Colour: black

- Working temp.: -50°C to +130°C

With male thread

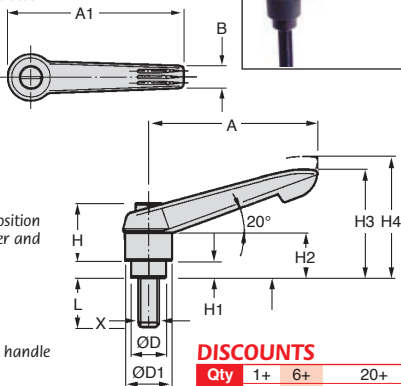

## Uses

- The lever is normally in a locked position
- Raise the handle to release the lever and turn to required position
- When handle is released, lever will automatically lock in new position

## Info.

- H4 = clearance height required for handle

## DISCOUNTS

Qty	1+	6+	20+
Disc.	List	-10%	On request

Part number		Threaded bolt X	H1	L			ØD	ØD1	H
Steel	Stainless			Steel	StS				
PCLA01T5	PCLA01T5SS	M5	4,0	50	25	10,0	13,0	24,5	
PCLA01T6	PCLA01T6SS	M6	4,0	50	50	10,0	13,0	24,5	
PCLA02T8	PCLA02T8SS	M8	6,5	60	60	13,5	18,0	28,5	
PCLA02T10	PCLA02T10SS	M10	6,5	60	60	13,5	18,0	28,5	
PCLA03T10	PCLA03T10SS	M10	10,0	60	60	16,0	21,5	37,0	
PCLA04T10	-	M10	10,0	90	-	19,0	25,5	43,0	
PCLA04T12	PCLA04T12SS	M12	10,0	90	60	19,0	25,5	43,0	
PCLA05T12	-	M12	12,0	90	-	23,0	30,0	49,0	
PCLA05T16	PCLA05T16SS	M16	12,0	90	60	23,0	30,0	49,0	

Part number		Stock*							Price each 1 to 5		
Steel	Stainless	A	H2	H3	H4	A1	B	Steel	StS		
PCLA01T5	PCLA01T5SS	40	15,0	30,0	33,5	47,0	7,5	✓	✓	9,83 €	13,52 €
PCLA01T6	PCLA01T6SS	40	15,0	30,0	33,5	47,0	7,5	✓	✓	9,83 €	14,53 €
PCLA02T8	PCLA02T8SS	65	17,5	41,5	45,5	75,0	9,5	✓	✓	11,46 €	17,36 €
PCLA02T10	PCLA02T10SS	65	17,5	41,5	45,5	75,0	9,5	✓	✓	11,46 €	17,36 €
PCLA03T10	PCLA03T10SS	80	24,0	53,5	58,0	91,5	11,0	✓	✓	14,14 €	21,57 €
PCLA04T10	-	95	26,0	61,0	66,0	109,0	13,0	✓	-	18,72 €	-
PCLA04T12	PCLA04T12SS	95	26,0	61,0	66,0	109,0	13,0	✓	✓	18,72 €	31,50 €
PCLA05T12	-	110	33,0	72,0	77,0	126,0	15,5	-	-	23,18 €	-
PCLA05T16	PCLA05T16SS	110	33,0	72,0	77,0	126,0	15,5	-	-	23,18 €	37,27 €

\*Depending on availability - Dimensions in mm

## Our other products



CHAsb28

Roll of hinge without pin, Plastic hinge

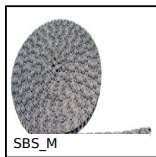

SBS\_M

Single chain supplied by the metre, Stainless steel



PRF-SRA

Lock for aluminium profile, Lock



BEK

Bearing housing for miniature ballscrew, Bearing housing



HTD8M-BAR

HTD type tooth bar stock, HTD8



PRF\_PF

Anchoring bracket for aluminium profile, Anchor

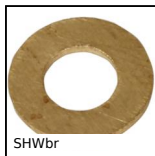

SHWbr

Washer - DIN125, Brass



PCLA\_T

Technopolymer clamping lever - male, Plastic



KKB-AR

Linear bearing with inclined ball tracks,



RT25ss

Self-centering flanged locking assembly,



BIM

Indexing plunger mini, miniature



CTZY

Diabolo shaped elasto mount, Steel

## Complementary products



CLB\_T

Die cast zinc clamping lever - male, Zamak



CLASS

Stainless steel indexing handle - male, Stainless steel



PCLA\_M

Technopolymer clamping lever - female, Plastic



CLB\_M

Die cast zinc clamping lever - female, Zamak