



DryLin® N miniature guiding system

Load up to 1000N

NK80
NW80

Small but
effective

- Linear rail with polymer slide
- Reduced size (both height and surface)
- Dry working, no maintenance required
- Not affected by dust
- Corrosion-resistant
- Reduced coefficient of friction means wear is reduced
- Reduced weight thanks to use of a combination of aluminium and plastic
- Very high speeds and acceleration possible
- Replaceable sliding parts in iglidur® J
- Materials:

Slide body: Plastic

Rails: Anodised aluminium

- Symmetrical hole pattern, C5=C6

Options

- Rail length up to 3960mm max.

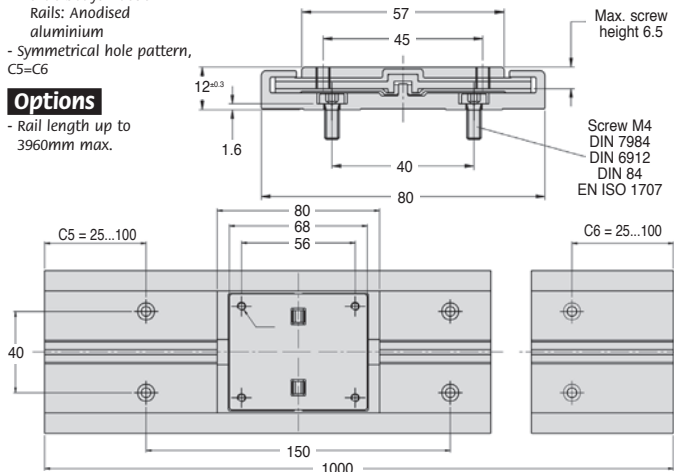
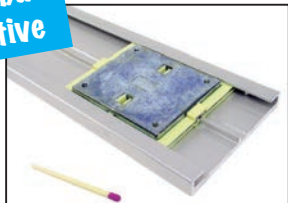

DISCOUNTS

| Qty | 1+ | 5+ | 10+ |
|-------|------|-----|------------|
| Disc. | List | -6% | On request |

| Part number | Type | Weight (g) | Stock* | Price each 1 to 4 |
|--------------|---------------------------|------------|--------|-------------------|
| NK02-80-1000 | 1 Rail (1000mm) + 1 slide | 1240 | ✓ | 106,74 € |
| NW02-80 | 1 slide only | 100 | ✓ | 14,12 € |

*Depending on availability - Dimensions in mm

Our other products



PFL

P-FLEX Coupling, Set screw



PCS6ECO

Chain sprocket - steel, 6mm (DIN 04-1)



PRS50

Stainless steel articulated foot Ø50, Ø 50



NPTF30

Fixed tube carrier, Fixed Ø14 to Ø20



CCL

Standard wire thimble, Steel



ACL

Joints for aluminium profile, Variable angle hinge



PW_PWG15

Wheel - precision range, Bronze



RLXAC8

Free roller, Steel



CHM40

Worm and wheel gear reducer, up to 57 Nm



HCA

Magnetic screw with socket, Steel



PSG2

Spur gear - precision range, Pre-hardened Steel 35NCD6



HTD3M_09

HTD Heavy duty timing pulley, HTD3 Aluminium

Complementary products



NSKB

Drylin® Rail end cap, Rail end cap