

Domino 80 adjustable slide



DOMI80

For C1 loads up to 500 N

- Suitable for heavy loads
- Low coefficient of friction
- High quality slideways
- Low backlash system
- Very fine adjustment (0.05mm)
- Standard axis lengths
- Simple control system

Applications

- Fine adjustment of brazing/welding heads or plasma cutting heads
- Inkjet printer head positioning
- Camera positioning
- Machine parts positioning (milling head, milling spindles,...)
- Burner focusing
- Laser head positioning
- Moving stops
- Centred movement for lateral guidance (slide with left-right pin)

Options

- Other stroke lengths available, please contact us for details
- If a digital counter is required to be fitted to the linear slide, replace /XY by Z in the part number

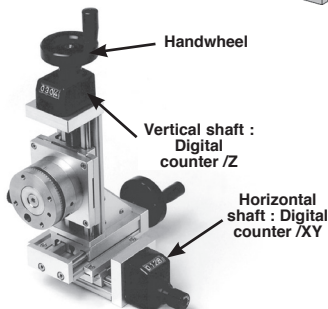
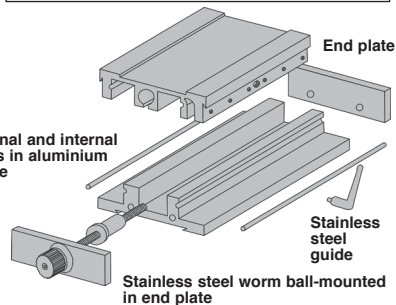
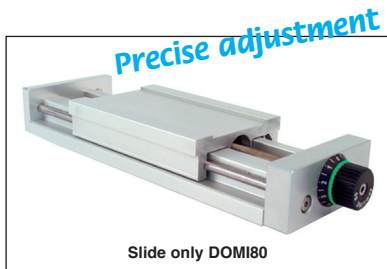

DOMI80-CV Adjustable slide fitted with handwheel and counter

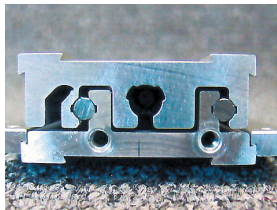

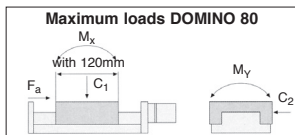
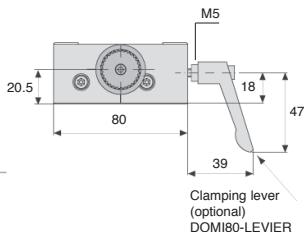
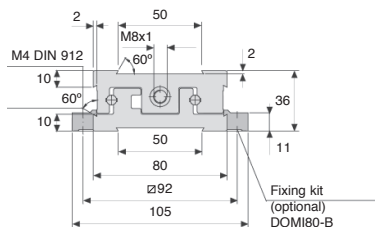
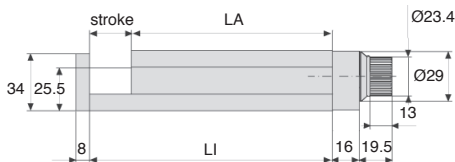

DISCOUNTS

Qty	1+	2+	3+
Disc.	List	-20%	On request

Part number	LA	LI	Stroke	Pitch (mm)	C1 (N)	C2 (N)	Maximum loads				Stock*	Price each
							FA (N)	Mx (Nm)	My (Nm)	Mz (Nm)		
Slide only												
DOMI80-25	120	145	25	1	500	365	150	8	10	6	✓	546,21 €
DOMI80-50	120	170	50	1	500	365	150	8	10	6	✓	556,92 €
DOMI80-75	120	195	75	1	500	365	150	8	10	6	-	569,77 €
DOMI80-100	120	220	100	1	500	365	150	8	10	6	-	580,48 €
Slide with counter and handwheel												
DOMI80-25-CV/XY	120	145	25	1	500	365	150	8	10	6	-	861,08 €
DOMI80-50-CV/XY	120	170	50	1	500	365	150	8	10	6	-	871,79 €
DOMI80-75-CV/XY	120	195	75	1	500	365	150	8	10	6	-	884,64 €
DOMI80-100-CV/XY	120	220	100	1	500	365	150	8	10	6	-	895,35 €

*Depending on availability - Dimensions in mm

DOMI80 For Domino 80 adjustable slides

- The **fastening kit** is used to attach the DOMINO adjustable slide to its mounting surface.
- The **machineable mounting plate** allows you to attach other equipment to the adjustable slide.

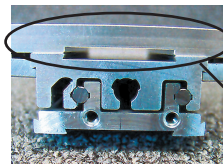

Tool plate support



Clamping lever
DOMI80-LEVIER



Fastening set
DOMI80-B

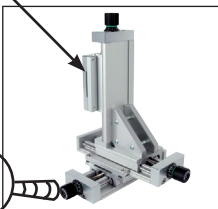

Typical application



Mounting plate
DOMI80-M

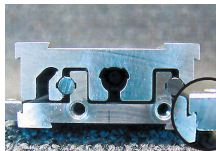

Assembly angle bracket

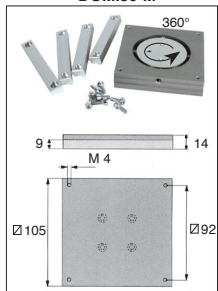

Turntable DOMI80-PT

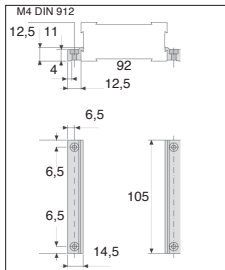

DOMI80-B fastening set

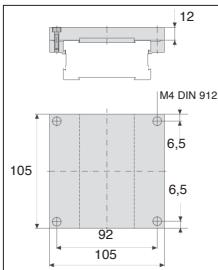

DOMI80-M mounting plate

DISCOUNTS

Qty	1+	2+	3+
Disc.	List	-20%	On request

Part number	Type	Stock*	Price each
DOMI80-B	Fastening set	✓	29,98 €
DOMI80-M	Mounting plate	✓	89,96 €
DOMI80-LEVIER	Clamping lever	✓	34,27 €
DOMI80-PT	Rotary turntable	-	419,83 €

*Depending on availability - Dimensions in mm

- **Connecting kits** are used to join two DOMINO adjustable slides.

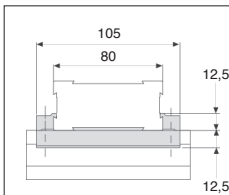

Connecting kit
DOMI 80-XY



Connecting kit DOMI80-XY



Connecting kit
DOMI 80-XZ

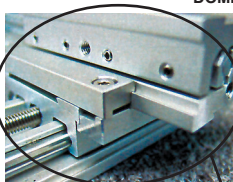

X-Y connecting kit

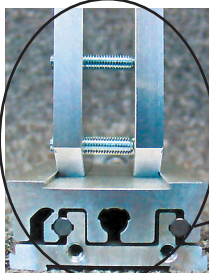

X-Z connecting kit

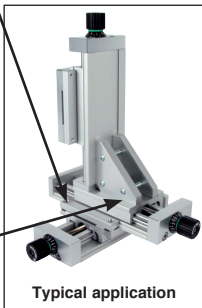

Typical application

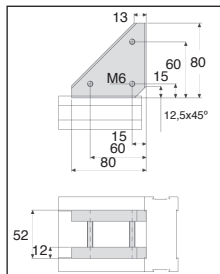

Connecting kit
DOMI 80-XZ

DISCOUNTS

Qty	1+	2+	3+
Disc.	List	-20%	On request

Part number	Type	Stock*	Price each
DOMI80-XY	Connecting kit X-Y	✓	72,82 €
DOMI80-XZ	Connecting kit X-Z	-	87,82 €

*Depending on availability - Dimensions in mm

Our other products



F7-SF-SM

Multifunction display,
Right angled
mounting bracket



PGM52-M4

Pull handle, Brass



SCH

Horizontal hook
toggle clamp,
Horizontal Hook
clamp - stainless steel



FCHN_CHNSS

Straight long link
chain, Galvanised
steel



Brush strip per meter
PA6 fibres Ø0.3 to
Ø0.5, Black polyamide
6 -...



BIMSS

Indexing plunger mini,
miniature - Stainless
steel



UGPL

Actuator guide kit,
Long bearing



F7-I

Multifunction display,
With internal sensor



BMM

Knurled knob - male,
Knurled



RLXAC8

Free roller, Steel



S20

Short housing for
open linear bearing,



RAM30

Manual bevel
gearbox, Bevel

Complementary products



DOMI80

Accessories, Clamping
lever



DOMI_MD

Domino rotary table,
55/1



DOMI80

Accessories, Fixing kit



DOMI80

Accessories, Plate