

Domino 30 adjustable slide



DOMI30

For C1 loads up to 150 N

- Suitable for heavy loads
- Low coefficient of friction
- High quality slideways
- Low backlash system
- Very fine adjustment (0.05mm)
- Standard axis lengths
- Simple control system

Applications

- Fine adjustment of brazing/welding heads or plasma cutting heads
- Inkjet printer head positioning
- Camera positioning
- Machine parts positioning (milling head, milling spindles,...)
- Burner focusing
- Laser head positioning
- Moving stops
- Centred movement for lateral guidance (slide with left-right pin)

Options

- Other stroke lengths available, please contact us for details
- If a digital counter is required to be fitted to the linear slide, replace /XY by Z in the part number

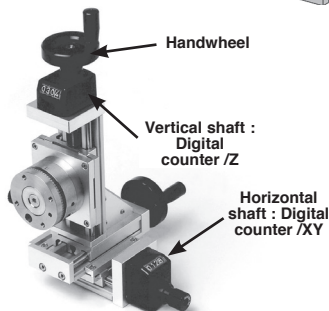
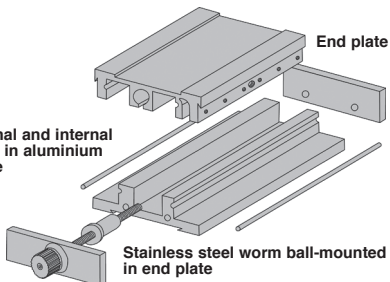
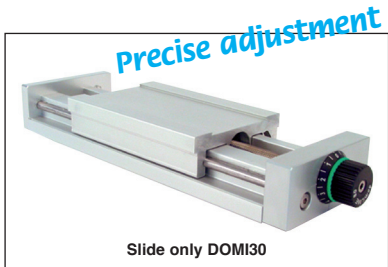

DOMI30-CV Adjustable slide fitted with handwheel and counter

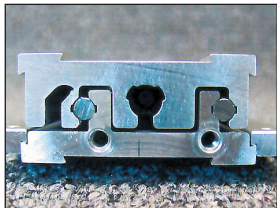

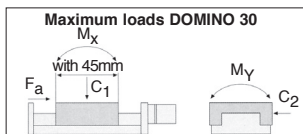
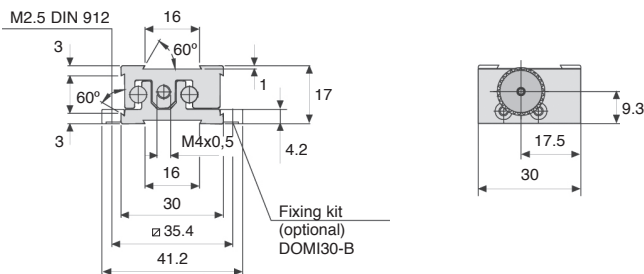
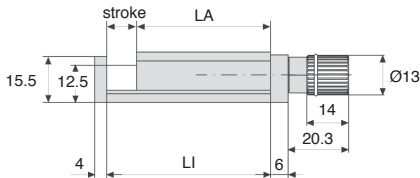

DISCOUNTS

Qty	1+	2+	3+
Disc.	List	-20%	On request

Part number	LA	LI	Stroke (mm)	Pitch (mm)	C1 (N)	C2 (N)	Maximum loads				Price each
							FA (N)	Mx (Nm)	My (Nm)	Mz (Nm)	
Slide only											
DOMI30-5	45	50	5	0,5	150	65	40	2	2	1	415,54 €
DOMI30-10	45	55	10	0,5	150	65	40	2	2	1	424,11 €
DOMI30-15	45	60	15	0,5	150	65	40	2	2	1	436,96 €
DOMI30-20	45	65	20	0,5	150	65	40	2	2	1	445,53 €
Slide with counter and handwheel											
DOMI30-5-CV/XY	45	50	5	0,5	150	65	40	2	2	1	730,42 €
DOMI30-10-CV/XY	45	55	10	0,5	150	65	40	2	2	1	738,99 €
DOMI30-15-CV/XY	45	60	15	0,5	150	65	40	2	2	1	751,84 €
DOMI30-20-CV/XY	45	65	20	0,5	150	65	40	2	2	1	760,41 €

Dimensions in mm



DOMI30 For Domino 30 adjustable slides

- The **fastening kit** is used to attach the DOMINO adjustable slide to its mounting surface.
- The **machineable mounting plate** allows you to attach other equipment to the adjustable slide.

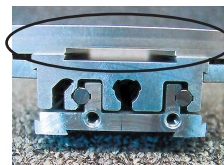

Tool plate support

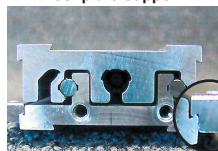

Assembly angle bracket

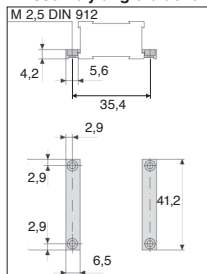

DOMI30-B fastening set

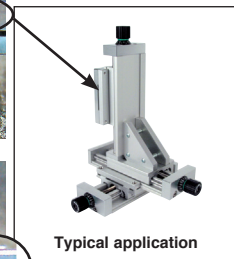

Typical application

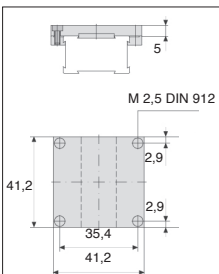

DOMI30-M mounting plate



Fastening set
DOMI30-B



Mounting plate
DOMI30-M

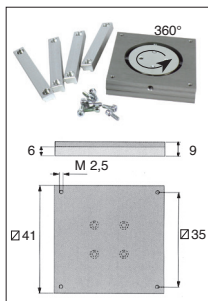

Turntable
DOMI30-PT

DISCOUNTS

Qty	1+	2+	3+
Disc.	List	-20%	On request

Part number	Type	Price each
DOMI30-B	Fastening set	23,56 €
DOMI30-M	Mounting plate	64,26 €
DOMI30-PT	Rotary turntable	359,85 €

Dimensions in mm



Connecting kits

For Domino 30 adjustable slides **DOMI30**

- **Connecting kits** are used to join two DOMINO adjustable slides.

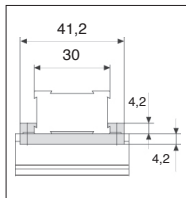

Connecting kit
DOMI30-XY



Connecting kit DOMI30-XY

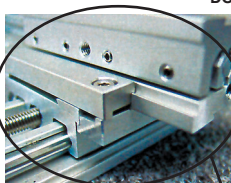

X-Y connecting kit

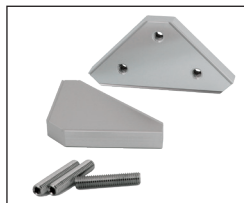

Connecting kit
DOMI 30-XZ

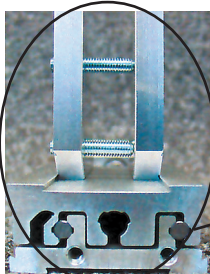

X-Z connecting kit

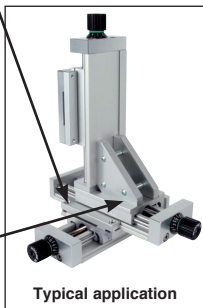

Typical application

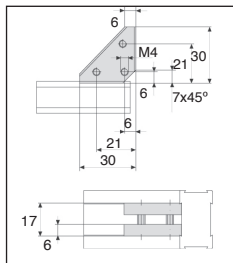

Connecting kit
DOMI30-XZ

DISCOUNTS

Qty	1+	2+	3+
Disc.	List	-20%	On request

Part number	Type	Price each
DOMI30-XY	Connecting kit X-Y	57,83 €
DOMI30-XZ	Connecting kit X-Z	66,40 €

Dimensions in mm

Our other products



BSM

Spring plunger with internal hexagonal socket, steel body and pin



MFBC

Flexible Bellows coupling, Aluminium and Bronze - with clamping jaw



H02SS

Needle roller universal joint - Stainless steel, Heavy duty DIN808-7...



PSEC

Security pull handle, Thermoplastic

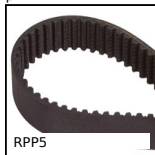

RPP5

RPP heavy duty timing belt, RPP5



MSP38

Masterplate® glueable insert Ø38, Cylindrical Ø38 with threaded s...

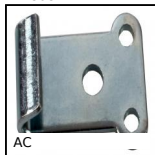

AC

Strike for toggle latch, 15mm



PFL

P-FLEX Coupling, Set screw

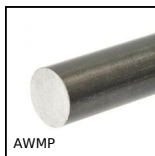

AWMP

Aluminium shaft for linear guide, Aluminium



BPVM

Miniature ball transfer unit, Miniature to screw

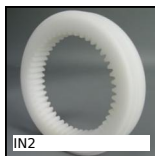

IN2

Internal gear, Machined plastic (delrin)



ACL

Joints for aluminium profiles, Variable angle corner

Complementary products



DOMI30

Accessories, Turntable



DOMI_MD

Domino rotary table, 55/1



DOMI30

Accessories, Fixing kit



DOMI30

Accessories, Plate