

Domino 120 adjustable slide



DOMI120

For C1 loads up to 1000 N

- Suitable for heavy loads
- Low coefficient of friction
- High quality slideways
- Low backlash system
- Very fine adjustment (0.05mm)
- Standard axis lengths
- Simple control system

Applications

- Fine adjustment of brazing/welding heads or plasma cutting heads
- Inkjet printer head positioning
- Camera positioning
- Machine parts positioning (milling head, milling spindles,...)
- Burner focusing
- Laser head positioning
- Moving stops
- Centred movement for lateral guidance (slide with left-right pin)

Options

- Other stroke lengths available, please contact us for details
- If a digital counter is required to be fitted to the linear slide, replace /XY by Z in the part number

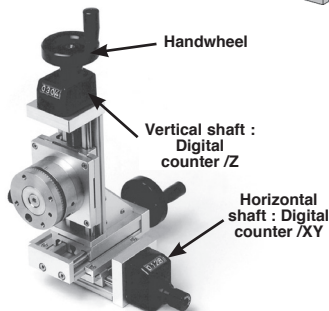
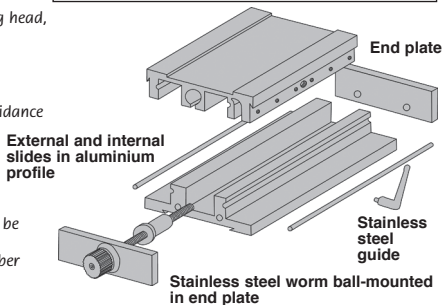

DOMI120-CV Adjustable slide fitted with handwheel and counter

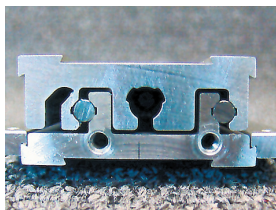

DOMI120

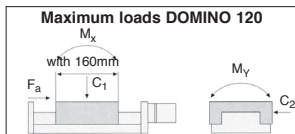
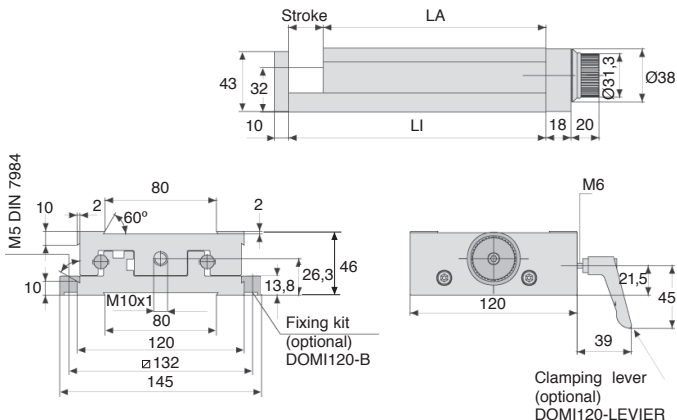

DISCOUNTS

Qty	1+	2+	3+
Disc.	List	-20%	On request

Part number	LA	LI	Stroke	Pitch (mm)	C1 (N)	C2 (N)	Maximum loads				Price each
							FA (N)	Mx (Nm)	My (Nm)	Mz (Nm)	
Slide only											
DOMI120-25	160	185	25	1	1000	700	300	15	20	12	771,12 €
DOMI120-50	160	210	50	1	1000	700	300	15	20	12	783,97 €
DOMI120-75	160	235	75	1	1000	700	300	15	20	12	798,96 €
DOMI120-100	160	260	100	1	1000	700	300	15	20	12	809,67 €
Slide with counter and handwheel											
DOMI120-25-CV/XY	160	185	25	1	1000	700	300	15	20	12	1 073,14 €
DOMI120-50-CV/XY	160	210	50	1	1000	700	300	15	20	12	1 036,98 €
DOMI120-75-CV/XY	160	235	75	1	1000	700	300	15	20	12	1 100,98 €
DOMI120-100-CV/XY	160	260	100	1	1000	700	300	15	20	12	1 133,83 €

Dimensions in mm



DOMI120 For Domino 120 adjustable slides

- The **fastening kit** is used to attach the DOMINO adjustable slide to its mounting surface.
- The **machineable mounting plate** allows you to attach other equipment to the adjustable slide.

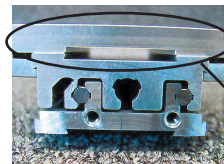

Tool plate support



Clamping lever
DOMI120-LEVIER



Fastening set
DOMI120-B

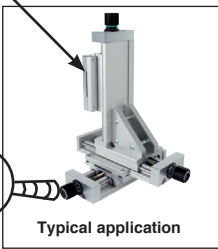

Typical application



Mounting plate
DOMI120-M

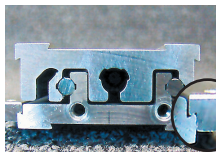

Assembly angle bracket

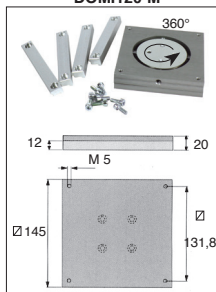

Turntable DOMI 120-PT

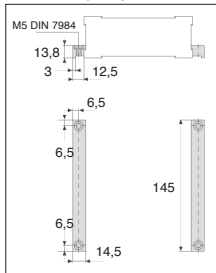

DOMI120-B fastening set

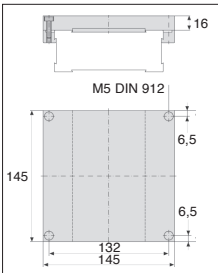

DOMI120-M mounting plate

DISCOUNTS

Qty	1+	2+	3+
Disc.	List	-20%	On request

Part number	Type	Price each
DOMI120-B	Fastening set	36,41 €
DOMI120-M	Mounting plate	130,66 €
DOMI120-LEVIER	Clamping lever	34,27 €
DOMI120-PT	Rotary turntable	563,34 €

Dimensions in mm



Connecting kits

For Domino 120 adjustable slides **DOMI120**

- **Connecting kits** are used to join two DOMINO adjustable slides.

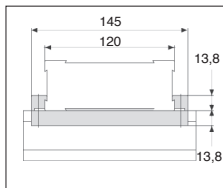

Connecting kit
DOMI120-XY



Connecting kit DOMI120-XY



Connecting kit
DOMI 120-XZ

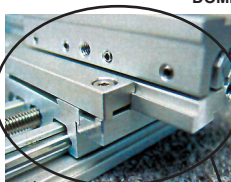

X-Y connecting kit

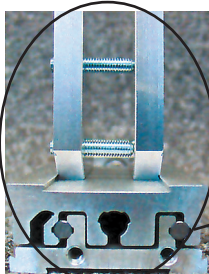

X-Z connecting kit

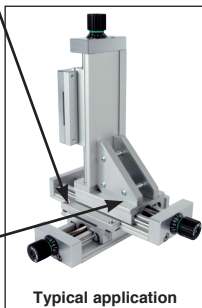

Typical application

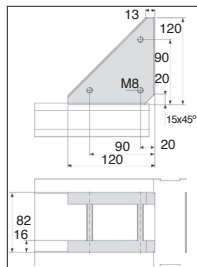

Connecting kit
DOMI120-XZ

DISCOUNTS

Qty	1+	2+	3+
Disc.	List	-20%	On request

Part number	Type	Price each
DOMI120-XY	Connecting kit X-Y	100,67 €
DOMI120-XZ	Connecting kit X-Z	128,52 €

Dimensions in mm

Our other products



CHN_CHN55

Straight long link stainless steel chain, Stainless steel



BGC

Oldham coupling, Clamp



G4-ECO

Eco range Spur gear, Steel C45



NT121

Spur gear coaxial gearbox, from 20 to 68 Nm - In-line



NPTR10

Adjustable cross clamp, Adjustable



MBF

Threaded blocking clamp, Threaded locking clamp



CMAss

Eye bolt stainless steel, Stainless steel



RPB

Ball screw bearing unit, Support



INS_SS

Self tapping stainless steel insert, Stainless



PT881

Drive sprocket for slat top chain, Range 881



KB_WW

Closed linear precision bearing,



MDB_MTB

Moulded plastic bevel gear (nylon), 2:1

Complementary products



DOMI120

Accessories, Clamping lever



DOMI_MD

Domino rotary table, 55/1



DOMI120

Accessories, Fixing kit



DOMI120

Accessories, Plate