

# Adjustment slide-system - Miniature size 20

## CQA

## Load 180N

### - Adjustment slide-system with dovetail joint

- Allows backlash-free adjustment for exact positioning and fixing.
- Several tables can be combined by using the connecting sets XY and XZ (adjustment screw Torx T7 M3x9 provided with the sets)

### -Material:

anodised aluminium without colorisation

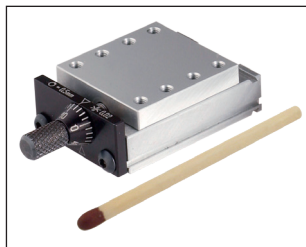

## Advantages

- Small footprint
- Backlash-free slide, axial or radial offset  $\leq 3 \mu\text{m}$ .
- Combination possible on different high speed shafts
- Micrometer scale

## Use

- Positioning of cameras, microscopes, laser heads
- 3D measurements
- Burner focusing
- Fine adjustment of brazing/welding heads

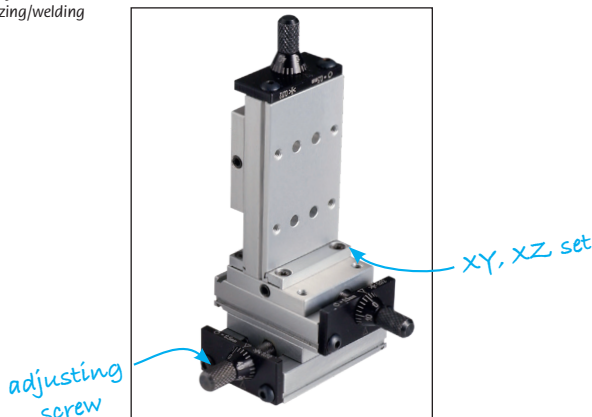

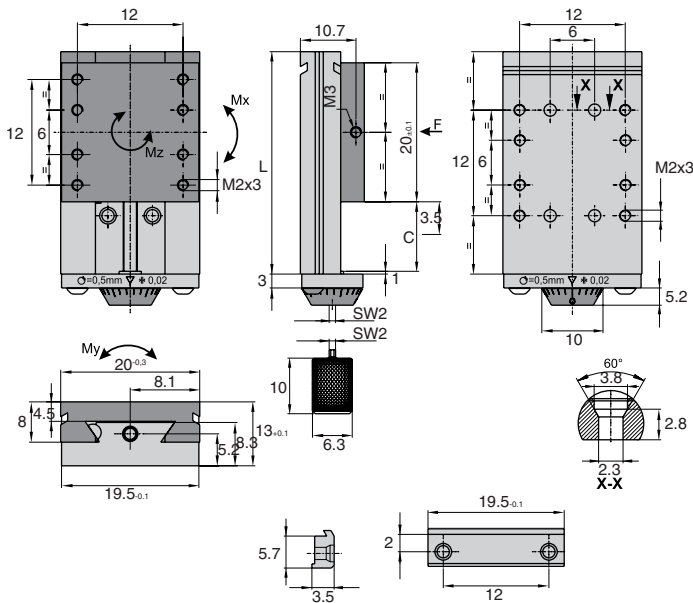

## DISCOUNTS

Qty	1+	2+	3+
Disc. Price	-15%	-15%	On request

Part number	Stroke L	Stroke C	Maximum loads				Weight (g)	Price per unit
			F (N)	Mx (Nm)	My (Nm)	Mz (Nm)		
<b>Adjustable slide</b>								
CQA20-5	30	5	180	0.45	2.0	0.30	30	461,44 €
CQA20-10	35	10	180	0.45	2.0	0.30	30	466,75 €
CQA20-20	45	20	180	0.45	2.0	0.30	30	474,70 €
<b>Accessories</b>								
CQA20-XY	Connection set XY							29,17 €
CQA20-XZ	Connection set XZ							37,12 €

Dimensions in mm