



# Spring loaded ball transfer unit

For heavy loads

BPHRF

- Ball transfer unit with solid body
- For heavy loads
- Machined bodies and covers
- Lubricated for life
- Orientation: horizontal with ball upwards
- Unique drainage hole
- Max. speed: 1.5m/s
- Working temperature range: -30 to +100°C
- Materials:  
Galvanised steel body and chromed steel balls



## Advantages

- Good resistance to shocks

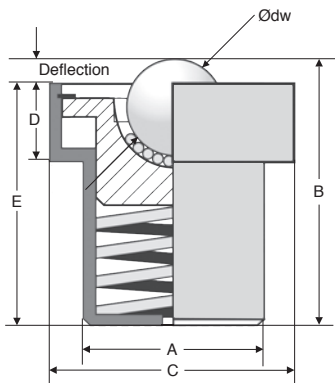

## DISCOUNTS

Qty	1+	6+	20+	40+	60+
Disc.	Net	-10%	-15%	-20%	On request

Part N°	Ødw ball	ØA	B	ØC	D	E	Carrying capacity (kg)	Load at max		Price each 1 to 5
								Deflection	deflection	
BPHRF22-39	22	39,0	58,0	50	14,0	53,5	70	4,5	90	66,18 €
BPHRF30-48	30	48,5	70,0	62	17,5	63,0	135	7,0	170	104,32 €
BPHRF45-66	45	66,5	100,5	85	25,5	90,0	230	10,5	290	136,41 €

All dimensions in mm

**0 825 88 6000**  
Service 0,15 €/min  
+ prix appel

Fax

cial2@hpceurope.com

**HPC**

SUPPLEMENT 2019

263

## Our other products



M0

Worm and wheel set,  
Bronze



BOX-TOR-H

Box set of Nitrile O-rings in nitrile, 3.00 x 2.00mm to 45.20 x 4.00



RCX-6

Spherical tilt washer -  
DIN6319, concave



CABma

Swaging sleeve for  
fitting cable, To crimp  
a wire rope



HLM5s

Revolving handle for  
handwheel, Stainless  
steel 316



H4

Crossed helical gear  
crossed axis at 90°,  
Steel 20NCD2



PCS8ECO

Chain sprocket - steel,  
8mm (DIN 05B-1)



BHC

Socket head button  
screw, Stainless steel  
A2



DOMI30

Domino 30 adjustable  
slide, Slide DOMILINE  
30 with counter and



SH3

Parallel axis helical  
gear, Steel 20NCD2



PITA

Locking bolt, with T  
handle



PSPE20

Conical flexible shaft  
handle Ø20, Black  
PVC

## Complementary products



BPHR

Ball transfer unit  
housed spring loaded,  
High