

Couvre-joint pour cardan

M

Caoutchouc

- Soufflets pour cardans simples
- Pour les cardans doubles, utiliser deux soufflets

Avantages

- L'emploi d'un soufflet permet de multiplier par 5 la durée de vie d'un cardan

Accessoires

- Voir guide achat **Cardans (tome 3 p.76)**



NOUVELLES
REMISES

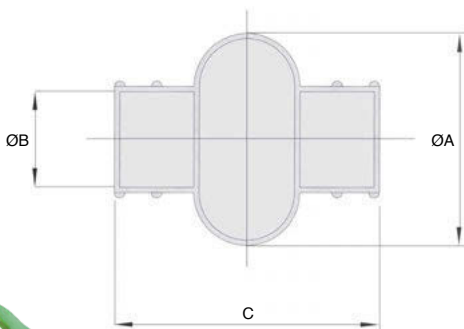

REMISES

Qté	1+	2+	4+	10+
Rem.	Prix	-6%	-12%	Sur demande

Références	Alésage de cardan (indicatif)	Pour cardan Øext	ØA	ØB	C	Stock*	Prix Uni.
M03-A-10	10	20-22	39	20,5	47	✓	9,84 €
M04-A-12	12	25	47	24,5	52	✓	9,84 €
M05-A-14	14	29	51	27,5	58	✓	9,84 €
M1-A-16	16	32	56	30,5	67	✓	10,77 €
M2-A-18	18	37	66	35,5	74	✓	10,77 €
M3-A-20	20	40	75	40,0	84	✓	15,40 €
M4-A-22	22	47	83	45,0	97	✓	15,40 €
M5-A-25	25	50	93	50,0	110	✓	16,71 €
M6-A-30	30	58	105	56,0	124	✓	16,71 €

*Dans la limite du disponible - Dimensions en mm