

- Chape à œil
- Anneau estampé et fermé
- Filetage ISO
- Matière : Acier brut

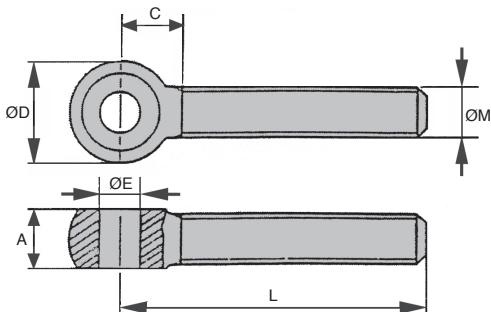

-24%^{0/**}

REMISES

Qté	1+	20+	40+	60+	80+	100+
Rem. Prix	-5%	-10%	-15%	-20%	Sur demande	

Références	ØM	L	A	C	ØD	ØE	Poids (kg)	Stock*	Prix Uni. 1 à 19
CMA1-06	M6	50	7	8,5	12	5	0,012	✓	5,87 €
CMA1-08	M8	60	9	11,1	16	6	0,025	✓	6,11 €
CMA1-10	M10	80	12	13,8	20	8	0,048	✓	8,44 €
CMA1-12	M12	90	14	16,4	24	10	0,088	✓	9,98 €
CMA1-14	M14	120	16	19,0	28	12	0,153	✓	13,25 €
CMA1-16	M16	140	18	21,0	32	14	0,303	✓	13,57 €
CMA1-18	M18	150	20	24,2	36	16	0,328	-	15,15 €
CMA1-20	M20	160	22	26,2	40	18	0,431	✓	18,81 €

*Dans la limite du disponible - Dimensions en mm - **Sur tarifs 2024

- Chape à oeil
- Inox
- Selon DIN444 forme B

Accessoires

- Petit volant VBFP (tome 1 p.129)

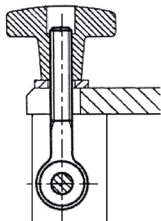

Exemple d'application

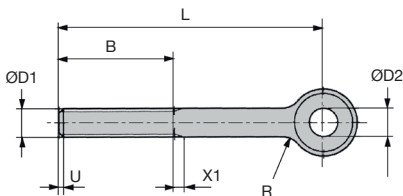
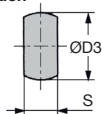

U = max 2 pas

X1 conforme à la DIN76

REMISES

Qté	1+	5+	10+	20+	30+
Rem.	Prix	-5%	-10%	-15%	Sur demande

Références	L	ØD1	ØD2	ØD3	B	S	R	Poids (kg)	Stock*	Prix Uni. 1 à 4
CMA1-05-50/SS	50	M5	5	12	16	6	2,5	0,011	✓	15,00 €
CMA1-06-50/SS	50	M6	6	14	18	7	4	0,016	✓	11,88 €
CMA1-06-75/SS	75	M6	6	14	18	7	4	0,021	✓	13,52 €
CMA1-08-50/SS	50	M8	8	18	22	9	4	0,030	✓	13,65 €
CMA1-08-75/SS	75	M8	8	18	22	9	4	0,040	✓	15,51 €
CMA1-10-75/SS	75	M10	10	20	26	12	4	0,055	✓	15,99 €
CMA1-10-100/SS	100	M10	10	20	26	12	4	0,070	✓	16,68 €
CMA1-12-75/SS	75	M12	12	25	30	14	6	0,085	✓	19,58 €
CMA1-12-100/SS	100	M12	12	25	30	14	6	0,100	-	21,50 €
CMA1-12-120/SS	120	M12	12	25	30	14	6	0,124	-	22,79 €
CMA1-12-130/SS	130	M12	12	25	36	14	6	0,135	✓	23,50 €
CMA1-16-130/SS	130	M16	16	32	44	17	6	0,244	-	42,21 €

*Dans la limite du disponible - Dimensions en mm