

Locking pin for bushes

BFD

Fast and light spring locking

- **Holding and centering pin**
- Locking element
- Materials:
 - Natural finish steel
- Temperature range: +180°C

Info

- Repeatability +/-0.25mm

Accessory

- Mounting pin BFD8-DLL

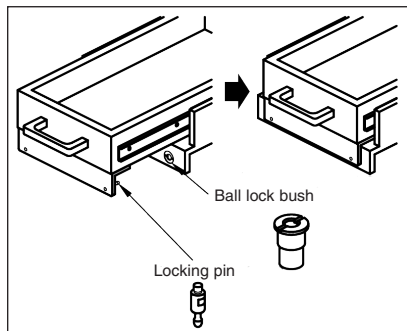

Example of use :
Attachment of a sliding unit

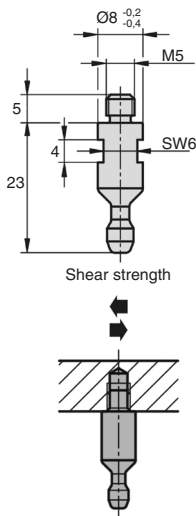

DISCOUNTS

Qty	1+	4+	8+
Disc. Price	-5%	On request	On request

Part N°	Shear strength (kN)	Price per unit 1 to 3
BFD8-23	1.8	4,70 €

Dimensions in mm

HPC

WEB
04/2021

www.hpceurope.com

Tél: 0 825 88 5000 Service 0,15€/min + prix appel

Ball lock bushes

Fast and light spring locking

BFDLL

- **Locking element to be associated with the BFD locking pin.**
- The 3 balls inside the bush hold the locking pin with the specified retaining force.
- **Materials:**
 Housing and locking element nickel-plated steel
 Ball: hardened stainless steel
 Spring: stainless steel
- Working temperature: up to 180 °C



Assembly

- Form A: min. plate thickness 6 mm.
- Form B: max. plate thickness 10 mm.
- Form C: plate thickness > 10 mm.
- Form D: blind hole.

Accessories

- Locking pin for bushes BFD8-23

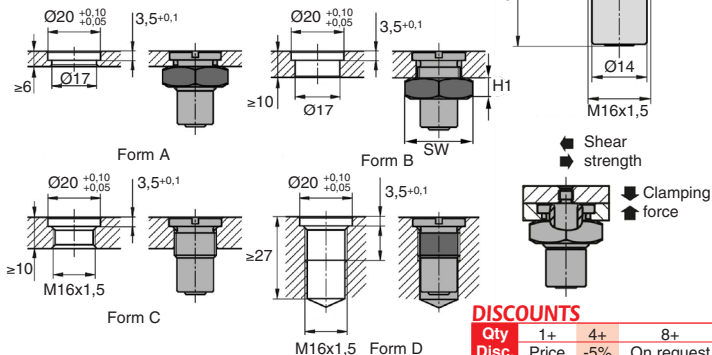

DISCOUNTS

Qty	1+	4+	8+
Disc. Price		-5%	On request

Part N°	Clamping force (N)	Shearing force (kN)	H1 SW		Price per unit 1 to 3
BFD8-7/DLL	7	1.8	-	-	30,00 €
BFD8-15/DLL	15	1.8	-	-	30,00 €
DLL-M16-EC	Nut for BFD8		8	24	0,69 €
DLL-M16-TOOL	Assembly tool				20,81 €

Dimensions in mm